

ELEVATION

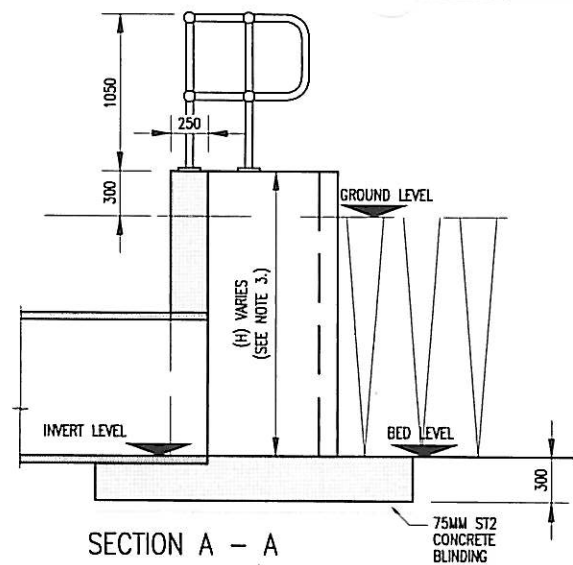

SECTION A - A

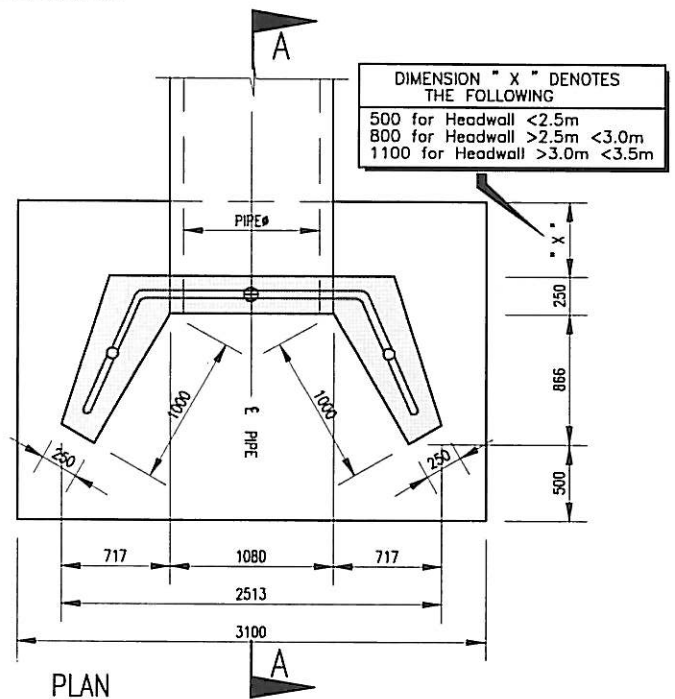

PLAN

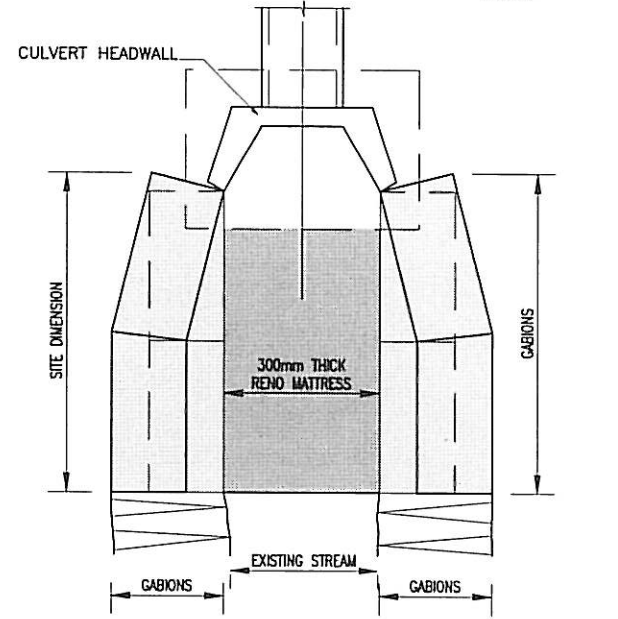

LAYOUT OF GABIONS AT HEADWALL

NOTES :

1. THIS RCD IS ONLY TO BE USED IN ASSOCIATION WITH A UNIQUE STRUCTURAL DESIGN CARRIED OUT FOR THE HEADWALLS ON A PROJECT IN ACCORDANCE WITH RELEVANT DESIGN CODES AND SITE GROUND CONDITIONS.
2. ALL EXPOSED CONCRETE SURFACES FROM 100MM BELOW GROUND LEVEL TO BE CLASS F3 FINISH. ALL OTHER CONCRETE SURFACES TO BE CLASS F1 FINISH UNLESS OTHERWISE SPECIFIED.
3. REFER TO DRAINAGE LONGITUDINAL SECTIONS AND/OR DRAINAGE SCHEDULES FOR PIPE DIAMETER SIZES, INVERT LEVELS AND HEADWALL HEIGHTS. MAXIMUM PIPE DIAMETER 900MM AND MAXIMUM HEADWALL HEIGHT (H) 3.5M.
4. HEADWALL WINGWALLS TO BE SLOPED WHERE APPROPRIATE AS SHOWN ON RCD/500/24.