

SECTION A-A

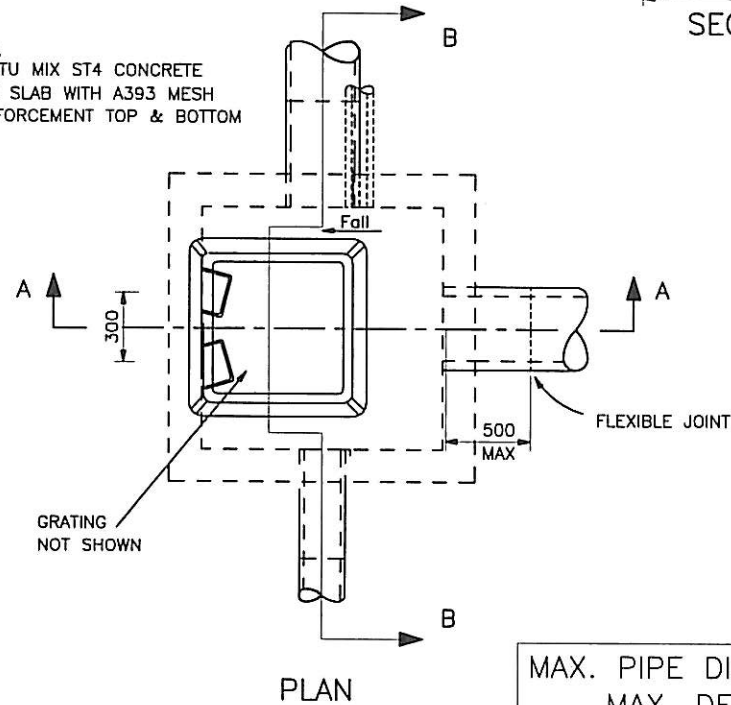
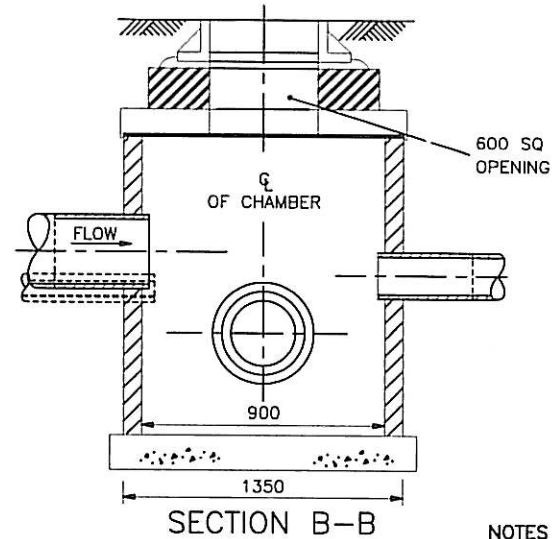

MAX. PIPE DIAMETER 450
MAX. DEPTH 1M

NOTES

1. ALL DIMENSIONS ARE IN MILLIMETRES.
2. CATCHPIT TO BE CONSTRUCTED IN 21N CONCRETE BLOCKS TO I.S. 20, COLOURED BLACK, WITH DESIGNATION 1 MORTAR AND TO SERIES 2400 OR IN-SITU MIX. ST4 CONCRETE.
3. FOR INVERT DETAILS, NUMBER OF BRANCHES, DETAILS OF PIPES AND TYPE OF GRATING COVER AND FRAME SEE THE DRAINAGE SCHEDULE.
4. MORTAR TO BE DESIGNATION (I) TO SERIES 2400.
5. PIPE TO BE BUILT INTO CATCHPIT TO DRAIN LOWER PORTION OF TRENCH. PIPE IS TO BE PLACED ABOVE ANY CONCRETE BED TO FILTER DRAIN.
6. THE GRATING AND COVER IS TO BE AS DIMENSIONED BELOW THE ADJACENT EDGE OF PAVEMENT WHERE PLACED IN THE VERGE OR MEDIAN. SET AT FINISHED LEVEL ALL OTHER LOCATIONS.
7. MAXIMUM PIPE DIAMETER PERMITTED IS 450mm. MAXIMUM DEPTH PERMITTED IS 1M PLUS PIPE DIAMETER.