

FOR LOOPS LAID IN REINFORCED CONCRETE
CONSTRUCTION
TYPE S1

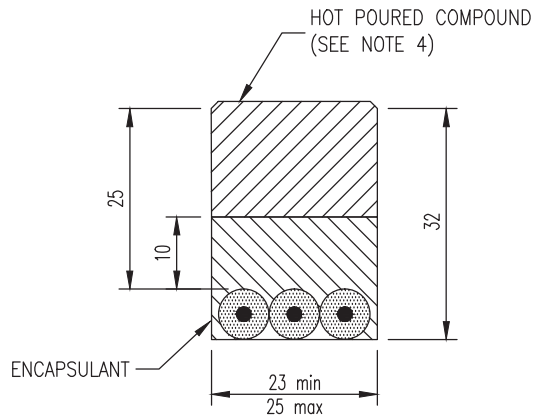

FOR LOOPS LAID IN NON-REINFORCED CONCRETE
CONSTRUCTION
TYPE S2

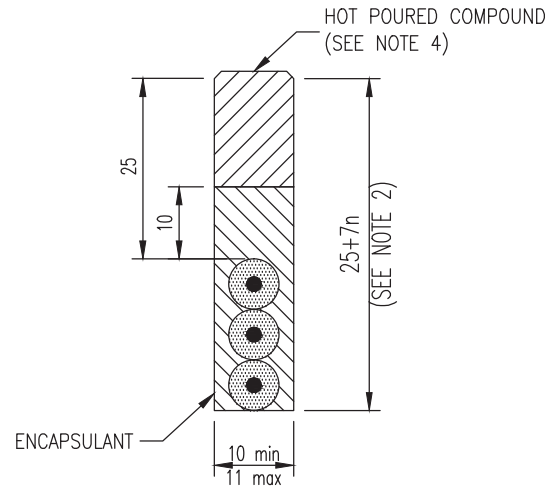

FOR LOOPS LAID IN FLEXIBLE
CONSTRUCTION
TYPE S3

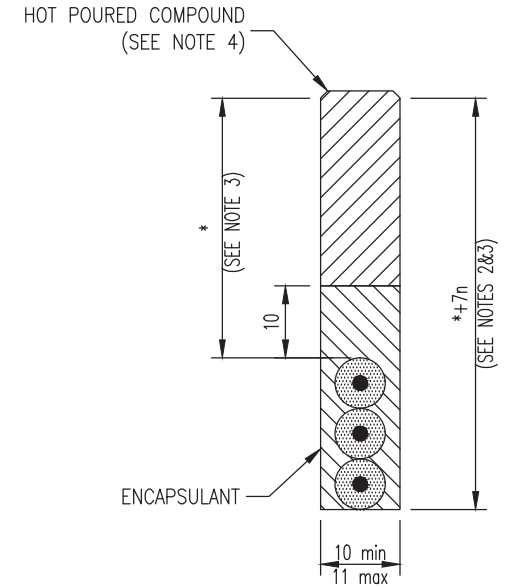

NOTES:

1. ALL DIMENSIONS ARE IN MILLIMETRES.
2. n = NUMBER OF CABLES IN THE SLOT.
3. * = UNLESS OTHERWISE SPECIFIED TO BE 80 FOR MOTORWAY APPLICATIONS AND 65 FOR ALL-PURPOSE ROADS.
4. HOT POURED COMPOUND SHALL BE OXIDISED GRADE BITUMEN TO IS EN 13304 AND IS EN 12591 GRADE S85/40 OR GRADE S85/25.
5. LOOP TAIL SLOT WIDTH SHALL BE 16 (+4/-0) WHERE TWISTED LOOP TAIL PAIRS OCCUPY THE SLOT.
6. FOR THE INSTALLATION OF DETECTOR LOOPS ON MOTORWAYS AND ALL PURPOSE DUAL CARRIAGEWAYS TO DMRB HD 20.

NOT TO SCALE

TII PUBLICATION NUMBER: CC-SCD-01525