

FOR DETAIL SEE
PART ELEVATION

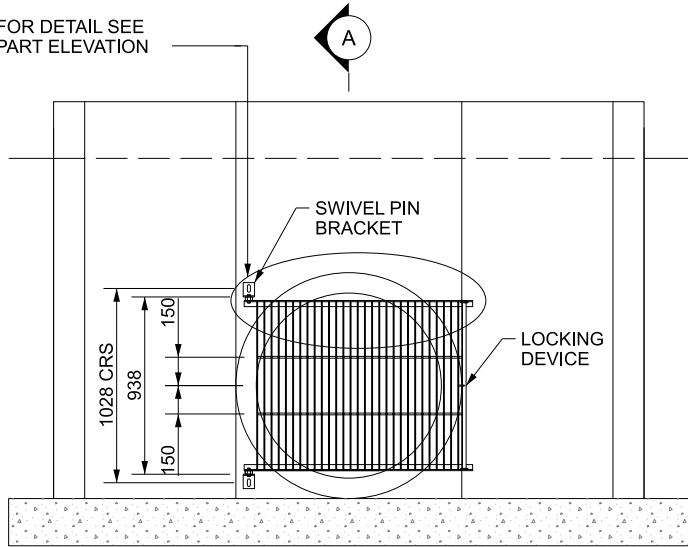

ELEVATION

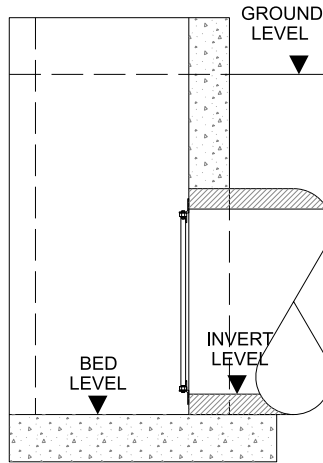

SECTION A-A

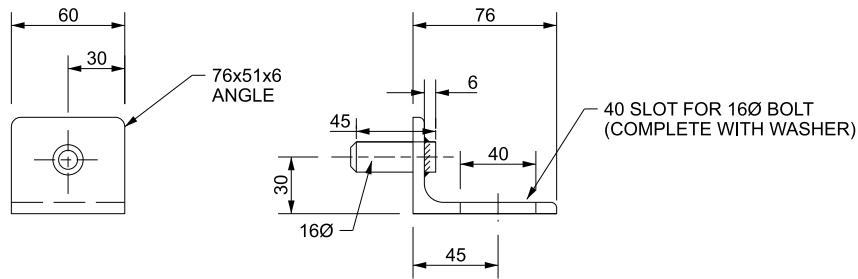

DETAILS OF SWIVEL PIN BRACKET

(SECURED TO PLATFORM WITH 16Ø BOLT)

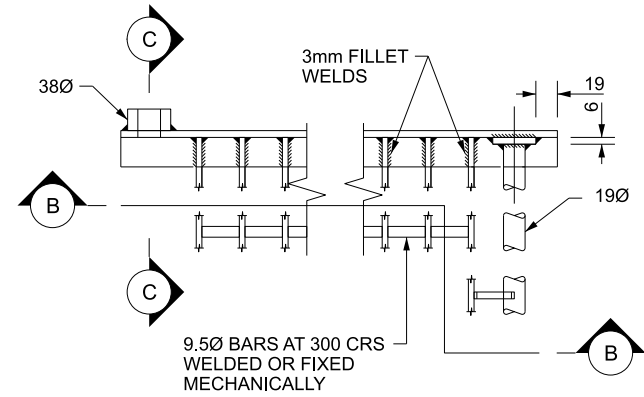

PART ELEVATION

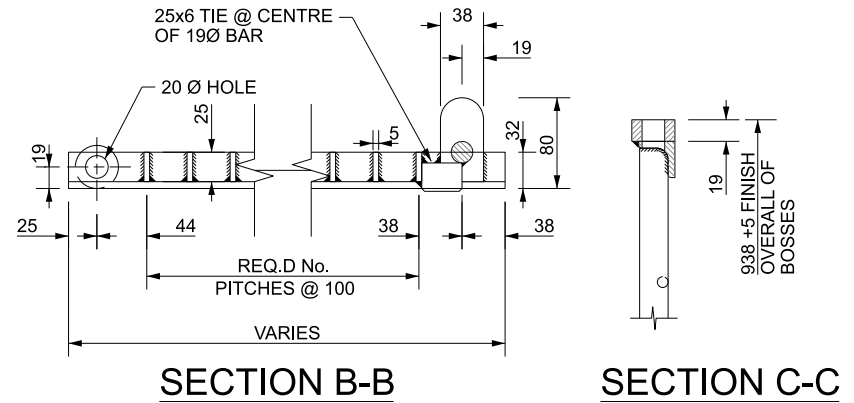



SECTION B-B

SECTION C-C

NOTES :

1. ALL DIMENSIONS ARE IN MILLIMETRES.
2. ALL WELDS ARE TO BE 6mm FILLET WELDS EXCEPT WHERE STATED OTHERWISE.
3. THE GRATINGS AND BRACKETS ARE TO BE FABRICATED FROM STEEL TO IS EN 10084 AND TO BE PROTECTED BY HOT DIP GALVANISING.
4. OUTLET GRID IS ONLY TO BE USED WHERE SELF CLEARING INLET GRID DETAILS TO CC-SCD-00551 IS PROVIDED.
5. PROPRIETARY SYSTEM MAY BE USED SUBJECT TO APPROVAL.

NOT TO SCALE

	ACTIVITY	PUBLICATION TITLE			
		DRAINAGE OUTLET GRID DETAIL			
STREAM	HISTORICAL REFERENCE	DOCUMENTATION SET	PUBLICATION DATE	PUBLICATION NUMBER	
STANDARD CONSTRUCTION DETAILS (SCD)	RCD/500/52	STANDARDS	FEBRUARY 2024	ACTIVITY	DRAWING NUMBER
				CC	SCD 00552