

- NOTES:
1. ALL DIMENSIONS ARE IN MILLIMETRES.
 2. ALL EXPOSED STEEL TO BE GALVANISED TO IS EN ISO 1461.
 3. PROPRIETRY INLET GRID MAY BE USED SUBJECT TO APPROVAL.

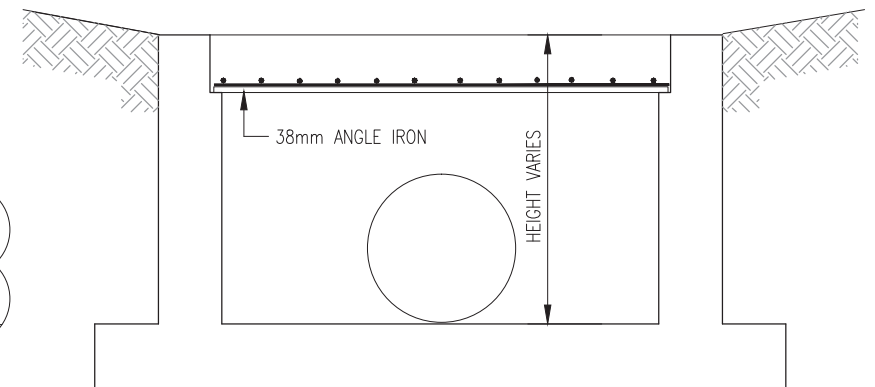
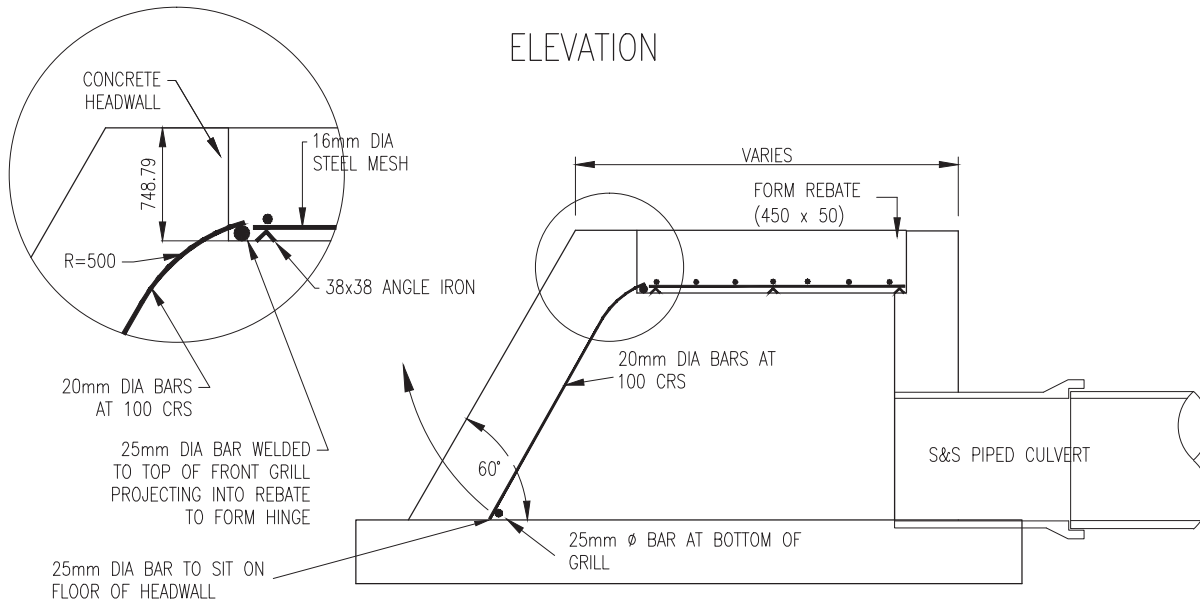
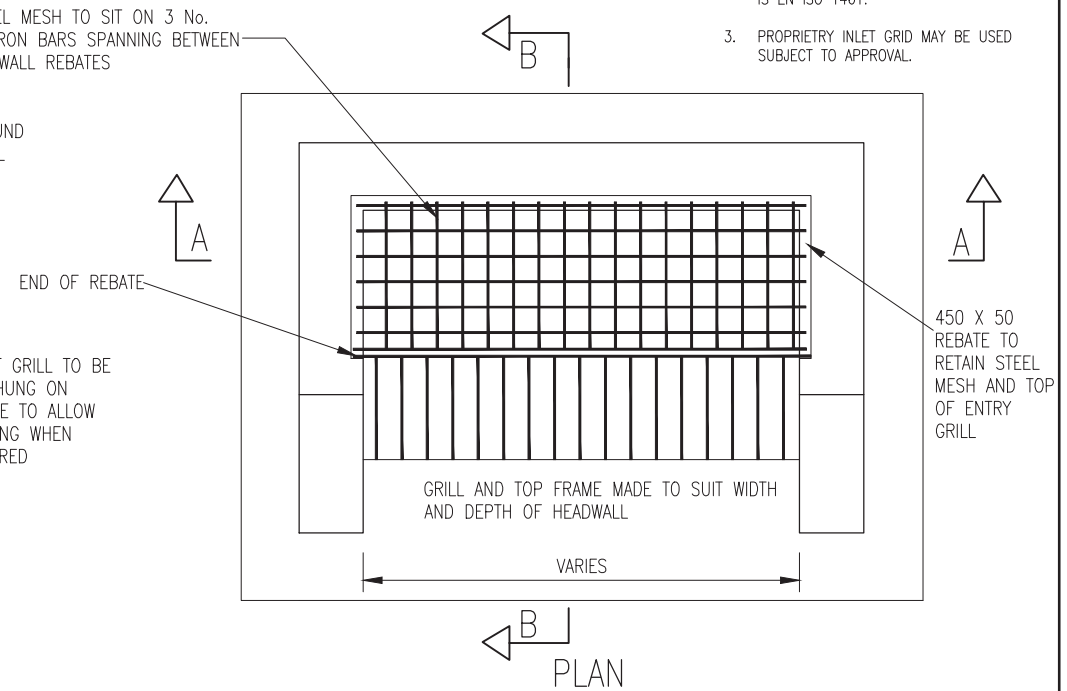
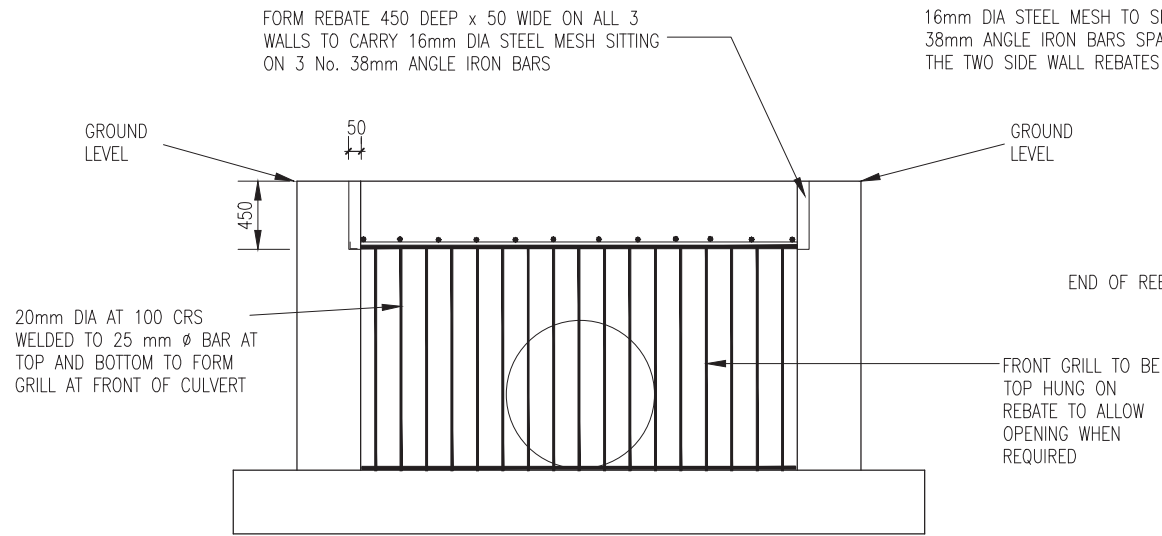

NOT TO SCALE

TII PUBLICATION NUMBER: CC-SCD-00551