

SECTION X-X

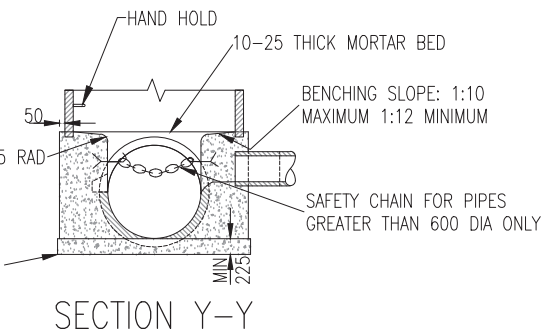

SECTION Y-Y

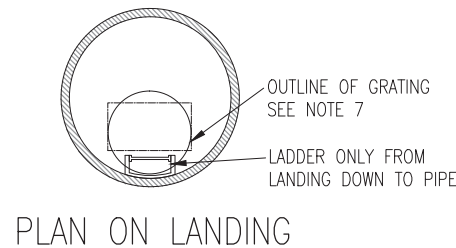
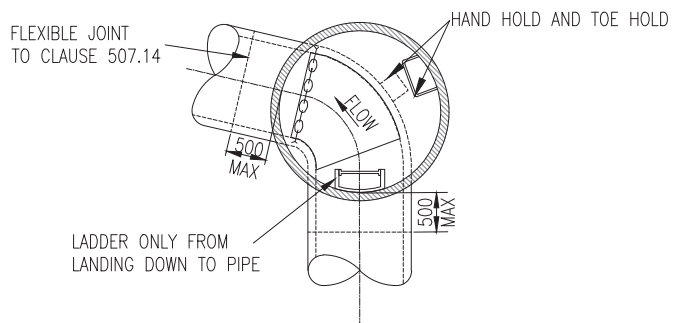

PLAN ON ANGLED INVERT
(UNDER LANDING SLAB)

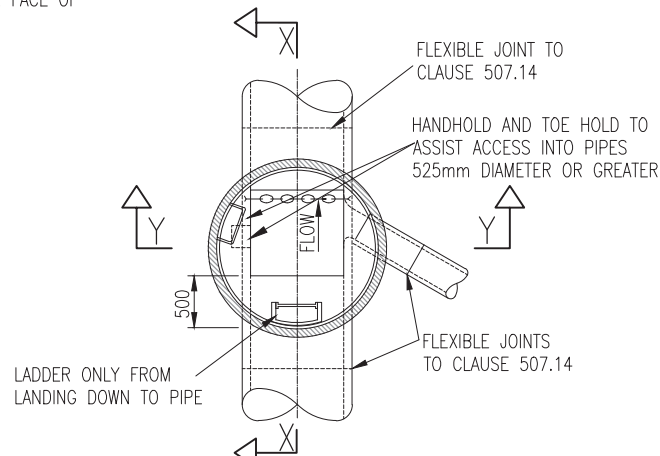

PLAN ON STRAIGHT INVERT
(UNDER LANDING SLAB)

NOTES:

1. ALL DIMENSIONS ARE IN MILLIMETRES.
2. CHAMBER WALLS, COVER SLAB AND LANDING SLAB TO BE CONSTRUCTED IN PRECAST CONCRETE TO BS 5911-3 AND IS EN 1917.
3. FOR INVERT DETAILS, NUMBERS OF BRANCHES, DETAILS OF PIPES AND TYPE OF COVER AND FRAME SEE APPENDIX 5/1.
4. MORTAR TO BE TO CLAUSE 507.13.
5. SAFETY CHAIN REQUIRED WHERE PIPE IS GREATER THAN 600 DIAMETER. FOR DETAILS OF SAFETY CHAIN, HANDHOLD AND LADDER SEE DRAWING No RCD/500/13.
6. FOR DETAILS OF HINGED GRATING SEE DRAWING No RCD/500/7.
7. TOE HOLD REQUIRED WHERE PIPE IS 525 DIAMETER OR GREATER SEE DRAWING No RCD/500/13.
8. MANHOLE COVER ARRANGEMENT IN CARRIAGEWAYS TO BE IN ACCORDANCE WITH RCD/500/14.
9. FLEXIBLE JOINTS TO BE IN ACCORDANCE WITH CLAUSE 507.14 AND RCD/500/14.

NOT TO SCALE



ROAD CONSTRUCTION
DETAILS

DRAINAGE

P5	03/15
P4	04/11
P3	01/09
Issue	Date

CHAMBER TYPE E
(PRECAST CONCRETE MANHOLE)

Drawing No.
RCD/
500/6

TII PUBLICATION NUMBER: CC-SCD-00506