

SECTION Y-Y

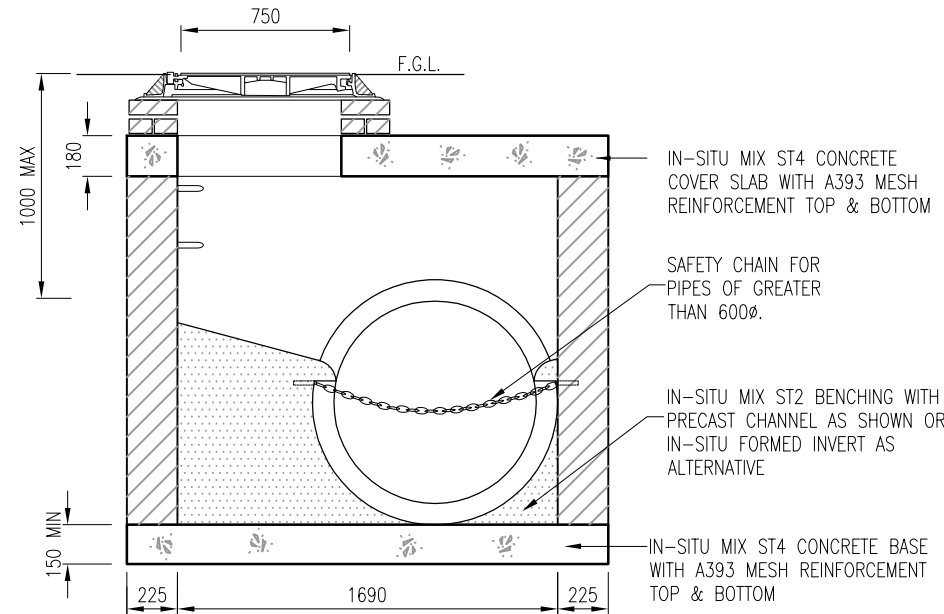

SECTION X-X

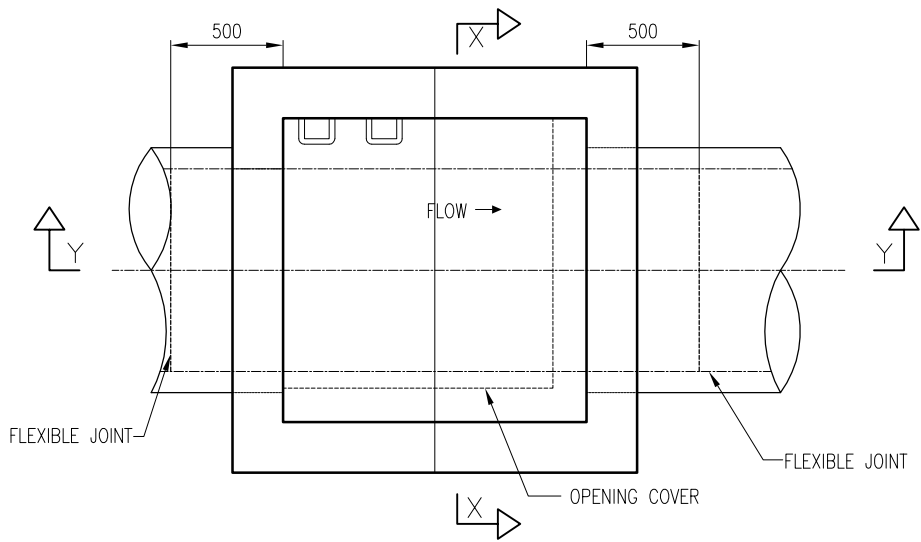

SECTIONAL PLAN

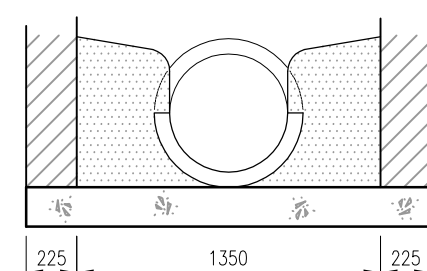

PART SECTION SHOWING BENCHING (FOR PIPES LESS THAN 600Ø)

NOTES:

1. ALL DIMENSIONS ARE IN MILLIMETRES EXCEPT WHERE STATED.
2. MANHOLES TO BE CONSTRUCTED IN 21N CONCRETE BLOCKS TO IS 20 COLOURED BLACK WITH MORTAR TO CLAUSE 507.17 OR IN-SITU MIX ST4 CONCRETE.
3. FOR INVERT DETAILS, NUMBER OF BRANCHES, DETAILS OF PIPES, TYPE OF COVER AND FRAME, SEE THE DRAINAGE SCHEDULE.
4. MANHOLE OPENING TO BE FURTHEST FROM THE NEAREST CARRIAGEWAY AND MANHOLE STEPS POSITIONED TO ALLOW VIEWING OF ONCOMING TRAFFIC.
5. CHAMBERS ON FOUL SEWERS TO BE PLASTERED.
6. DIMENSIONS OF CHAMBER VARY ACCORDING TO PIPE SIZE SEE RCD/500/3.

NOT TO SCALE