

MANHOLE TYPES ----- DRAINAGE PIPES

NOTES:

1. ALL DIMENSIONS ARE IN MILLIMETRES. EXCEPT WHERE STATED.
2. DEPTH IN THIS MANHOLE SCHEDULE IS DEFINED AS DEPTH FROM MANHOLE COVER TO THE HIGHEST PIPE SOFFIT IN THE MANHOLE. THIS DIFFERS FROM DEPTH AS DEFINED IN MMRW.

DEPTH (m)	PIPE DIAMETER								
	225	300	375	450	525	600	675	750	900
0 → 1	A 975x1350	A 975x1350	A 975x1350	A 975x1350	B1350x1690	B1350x1690	B1350x1690	B1350x1690	B1350x1690
1 → 3	C 1500	C 1500	C 1500	C 1500	C 1500	C 1500	C 1500	C 1500	C 1500
3 → 5		D 1500	D 1500	D 1500	D 1500	D 1500	D 1500	D 1500	D 1500
5 → 6		E 1500	E 1500	E 1500	E 1500	E 1500	E 1500	E 1500	E 1500
6 → 12		F 1500	F 1500	F 1500	F 1500	F 1500	F 1500	F 1500	F 1500

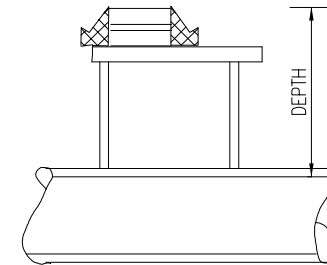
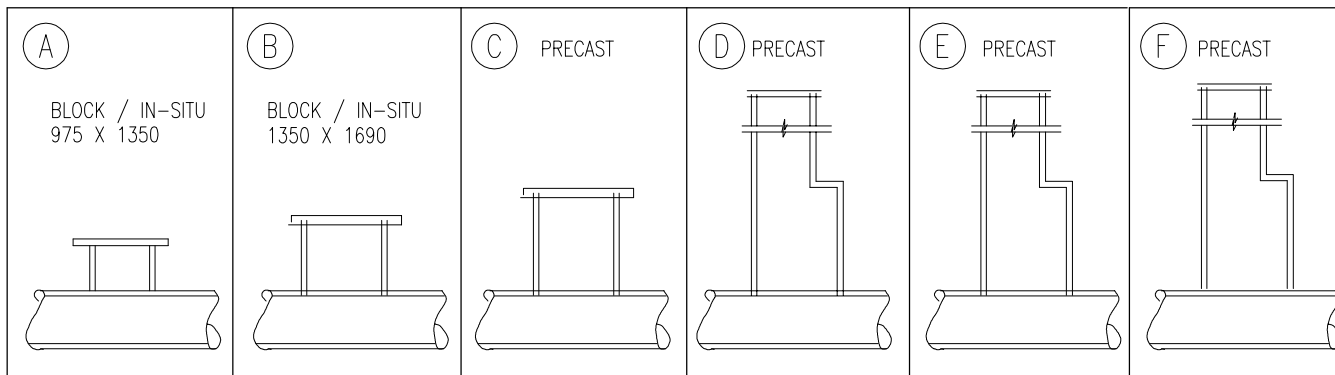

NOT TO SCALE