

Fix mesh to posts using 40mm x 4mm Ø galvanised staples on every second horizontal line wire

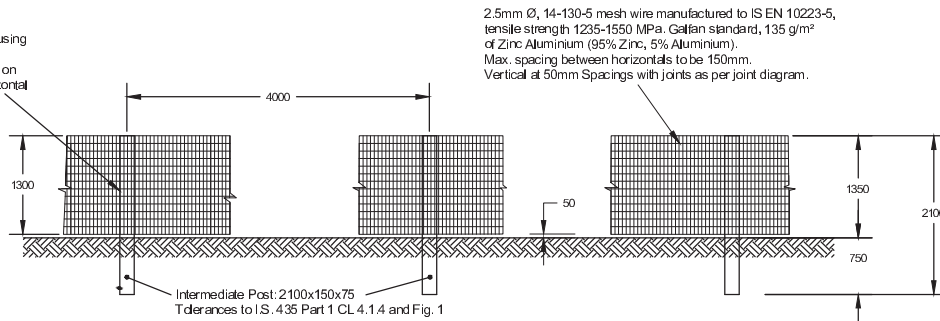

FENCE ELEVATION

FENCE PLAN

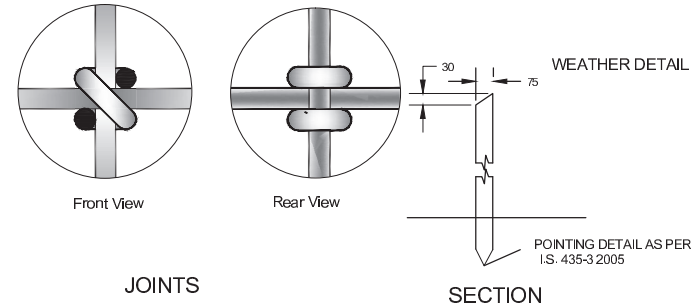

JOINTS

SECTION

NOTES:

- FENCES SHALL BE CONSTRUCTED AND ERECTED IN ACCORDANCE WITH I.S. 435, 2005 EXCEPT WHERE OTHERWISE SHOWN.
- ANY LENGTH OF FENCING (INCLUDING BRANCHES OR SPURS) SHALL START WITH A STRAINING POST AND END WITH A STRAINING POST. ADDITIONAL STRAINING POSTS SHALL BE PROVIDED AT FENCE JUNCTIONS AND AT FENCE CORNERS WHERE AT CURVES AND ANGLES. WHERE STRAINING POSTS ARE TO BE DRIVEN, THEY SHOULD BE POINTED PRE-TREATMENT.
- STANDARD POST HOLES FALLING IN ROCK TO BE EXCAVATED TO THE DEPTH SHOWN ON THIS DRAWING OR, WITH THE EMPLOYERS REPRESENTATIVES APPROVAL, TO A DEPTH OF 500mm, AND SHALL BE BACK FILLED WITH MIX ST2 CONCRETE. WHERE A REDUCED DEPTH OF HOLE IS AGREED, THE TOP OF THE POST SHALL BE SUITABLY CUT AND TREATED IN ACCORDANCE WITH THE RECOMMENDATIONS OF I.S. 435:2005. END POST HOLES TO BE EXCAVATED TO 1.1m.
- FENCE POSTS SHALL BE TREATED WITH PRESERVATIVE IN ACCORDANCE WITH THE REQUIREMENTS OF SERIES 300 OF THE NRA SPECIFICATIONS FOR ROAD WORKS AND WITH APPENDIX B OF IS 435-1: 2005
- WHERE SIDELONG GROUND SLOPES DOWN TOWARDS THE FENCE AT A SLOPE GREATER THAN 1:4 THEN THE PERMANENT FENCING POST HEIGHT SHALL BE INCREASED BY A MINIMUM OF 250mm
- WHERE THERE IS AN INSTANTANEOUS CHANGE IN DIRECTION OF THE FENCE GREATER THAN 20°, THE 2100 X 150 X 75 POSTS SHOULD BE SUBSTITUTED WITH ROUND 2500MM X 170MM DIAMETER POSTS. POST SPACING SHOULD BE REDUCED TO 2000mm UNTIL THE CHANGE IN DIRECTION IS LESS THAN 20°.
- WHERE A CHANGE IN DIRECTION OF THE FENCE LINE IS GREATER THAN 30° A DOUBLE END POST ASSEMBLY SHOULD BE INSTALLED
- ON CURVES THE WIRE SHOULD ALWAYS BE ON THE OUTSIDE OF THE CURVE WITH THE WIRE PRESSING AGAINST THE POST.
- WIRE MESH SHOULD BE TIED AROUND THE END POST BY TYING THE HORIZONTAL LINE WIRES AROUND THE END POST AND WRAPPING AROUND FIVE TIMES BACK ONTO THEMSELVES. ALTERNATIVELY GRIPPLE T-CLIPS OR SIMILAR WIRE JOINING DEVICES CAN BE USED FOR THIS PURPOSE. THE WIRE SHOULD NOT BE STAPLED TO THE END POST.
- SECURE WIRE MESH TO FIELD SIDE OF POSTS WITH WIRE STAPLES WIRE STAPLES SHALL BE GALVANISED 40mm x 4mm ROUND, EXCEPT WHERE THERE IS A CURVE. SEE NOTE 8.
- ROLLS OF THE WIRE MESH SHOULD BE JOINED USING CRIMPING SLEEVES OR GRIPPLE-TYPE WIRE JOINERS. THE RECOMMENDED TENSION FOR THE WIRE MESH IS 45.5KG/M PER LINE WIRE.
- WHERE STATED IN APPENDIX 3/1 CONCRETE FOOTINGS TO POSTS SHALL BE PROVIDED.
- END POST ASSEMBLY MUST BE PROVIDED AT THE START AND END OF A FENCE RUN AND SHOULD BE NO MORE THAN 150m APART. A DOUBLE END ASSEMBLY SHOULD BE PROVIDED WHERE THE FENCE LINE TURNS AT AN ANGLE OF MORE THAN 30°.
- POST DIAMETERS MUST BE SUCH THAT THE CROSS SECTIONAL AREA SHALL NOT EXCEED THE LIMITS SPECIFIED IN NRA TD 19/14. SUCH THAT THE POST WOULD BE CONSIDERED TO BE A HAZARD.
- WHERE FENCE IS REQUIRED TO BE MAMMAL RESISTANT, THE MESH SHALL PROTRUDE BELOW GROUND LEVEL AS PER RCD 300/19. IN SUCH INSTANCES A WIDER MESH TYPE SHALL BE REQUIRED TO ACHIEVE THE SPECIFIED MESH HEIGHT ABOVE GROUND LEVEL.

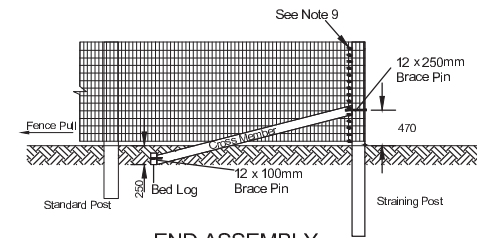

END ASSEMBLY ELEVATION



END ASSEMBLY PLAN

End Assembly Details		
Item	Quantity	Description
Straining Posts	1	2500mm x 170mm minimum Ø Timber Post
Cross Member	1	2700mm x 100mm minimum Ø Timber post
Brace Pin	1	12mm x 250mm Galvanised Pin
	1	12mm x 100mm Galvanised Pin
Bed Log	1	150mm x 75mm x 460mm minimum Timber post
Gripple T-Clips	13	Galvanised Wire Joiners

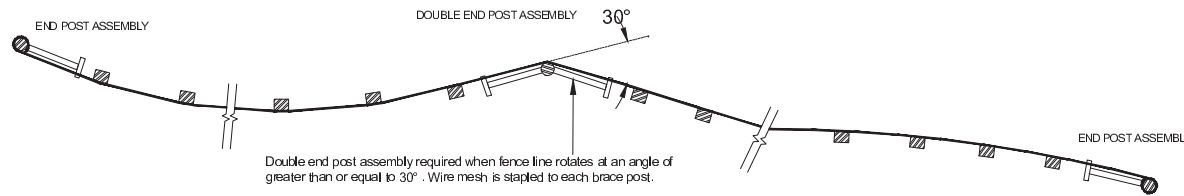

END POST ASSEMBLY FOR CURVED FENCE LINE

TII PUBLICATION NUMBER: CC-SCD-00320