

ELEVATION

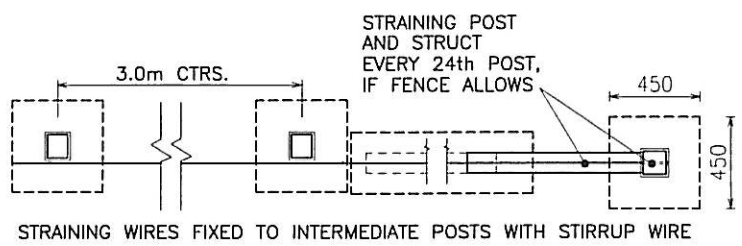

PLAN

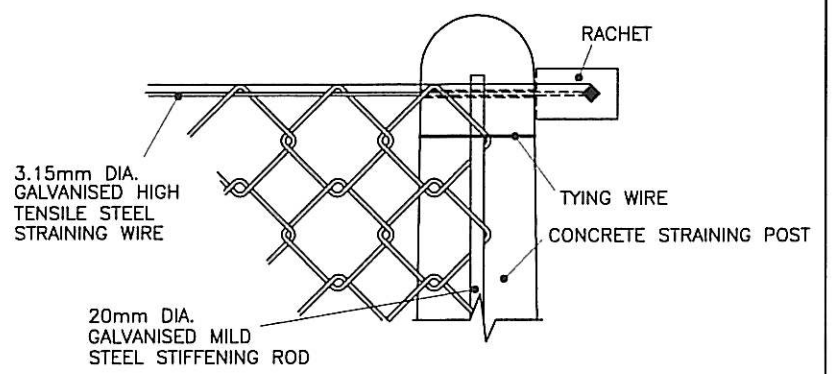

DETAIL SHOWING CHAINLINK STRAINING WIRE ETC

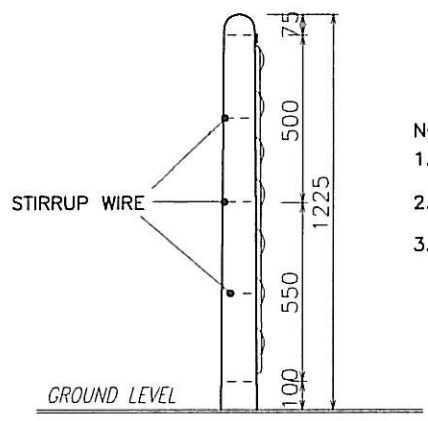

SECTION INTERMEDIATE POST

- NOTES :
1. ALL DIMENSIONS ARE IN MILLIMETRES.
 2. CONCRETE POST SHALL COMPLY WITH I.S. 252.
 3. BARBED WIRE WHERE REQUIRED SHALL BE SPECIFIED IN APPENDIX 3/1 TO THE SPECIFICATION.

P1	03/00
Issue	Date